

Koroseal Wall Protection Systems

Bellagard® Chair Rails

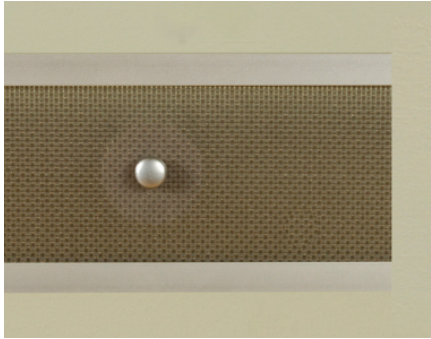

BellaLucent Rail



BellaStone Rail



BellaLaminate Rail

U-Channel Top Cap with U-Channel Bottom

Now you can have it all—beauty and functionality in one unique wall finishing. Designed for use in high visibility areas, **BELLAGARD®** is a flexible option for lobbies, conference rooms, hallways, and other areas where beauty and functionality are a must.

Chair rails are available in four materials including BellaLucent, BellaStone, BellaLaminate, and Elegant Wood. With each option, you may select your choice of U-channel top and bottom caps, which can be specified in either wood or aluminum. Caps are available in a variety of colors and wood species to create a chair rail that perfectly complements your interior environment.

- BellaLucent Rails are 1/2" -thick (12.7mm) translucent high-performance composite with Sandstone surface texture. Multiple colors and wood species are available, as are 11 BellaLucent patterns.
- BellaStone Rails are 1/2" -thick (12.7mm) non-porous, high-performance solid acrylic. Multiple colors and wood species are available, as are 12 BellaStone colors.
- BellaLaminate Rails are 1/2" -thick (12.7mm) and available in 6 different patterns.
- Elegant Wood Rails are 1/2" -thick (12.7mm) and available in 6 different species with 17 stain options.

FSC Certified Wood is available for Bellagard Chair Rails.

For more information on **BELLAGARD** Chair Rails or the **KOROSEAL** Wall Protection System, please call your local **KOROGARD** distributor or 800-628-0449.

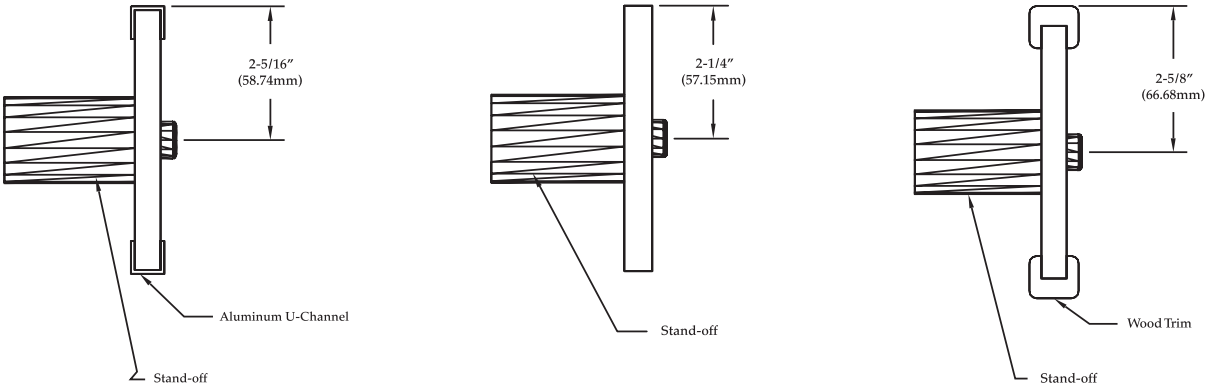

Product Guide Specification

SECTION 10 26 00 CHAIR RAILS

PART 1 GENERAL

1.01 SUMMARY

Section Includes:
Decorative Chair Rail Systems

1.02 SUBMITTALS

- A. Comply with Section 01 33 00.
- B. Product Data: Submit manufacturer's product data.
- C. Shop Drawings: Submit shop drawings showing components, dimensions, and mounting details.
- D. Samples: For selection of models, colors, patterns, and finishes. 12-inch (300mm) long samples of each type chair rail required.

1.03 QUALITY ASSURANCE

- A. Single Source Responsibility: Obtain chair rail system components from a single source.
- B. Deliver materials in original factory wrappings and containers, clearly labeled with manufacturer brand name.
- C. Store materials in original undamaged packages and containers inside a well-ventilated area protected from weather, moisture, soiling, extreme temperatures, and humidity.
 1. Maintain room temperature within the storage area between 60°F (16°C) and 80°F (27°C) during the period plastic materials are stored. Keep materials out of direct sunlight to avoid excessive surface temperatures.
 2. Store chair rail materials in a horizontal position for a minimum of 72 hours, or until the material attains the ambient room installation temperature of between 65°F (18°C) and 75°F (24°C).

1.04 PROJECT CONDITIONS

- A. Maintain ambient temperature within building at not less than 65°F (18°C) or greater than 75°F (24°C) for a minimum 72 hours prior to beginning of installation.
- B. Do not install chair rail system components until the space is enclosed, weatherproof and climate controlled.
- C. Do not install rail systems until temperature is stable and permanent lighting is in place.

1.05 MAINTENANCE

- A. Maintenance Instructions: Include precautions against cleaning materials and methods that may be detrimental to finishes and performance.
- B. Replacement Materials: Minimum 2 percent of each type, color, and pattern of materials and components. Include accessory components as required. Replacement materials shall be from the same production run as installed materials. Package with protective coverings and appropriate labels.

PART 2 PRODUCTS

2.01 MANUFACTURER

Koroseal Wall Protection Systems
A Division of RJF International Corporation.

2.02 CHAIR RAIL SYSTEMS

"Bellagard" by Korogard: Chair Rail system supplied factory-fabricated, -finished, and -assembled for installation with supplied mounting blocks.

1. Wood: Select species and stain from manufacturer's selection.
2. Accents: Select type, color, and pattern from manufacturer's selection.
3. Trim: Select aluminum or wood from manufacturer's selection.
4. Stand-Off: Select aluminum, clear acrylic, or wood from manufacturer's selection.

2.03 MATERIALS

- A. Solid Wood Components: Shall be kiln-dried FAS grade hardwood. All wood components shall be factory finished.
- B. BellaStone Rails: Shall be 1/2"-thick (12.7mm) non-porous, high-performance solid acrylic.
- C. BellaLucent Rails: Shall be 1/2"-thick (12.7mm) translucent, high-performance composite with Sandstone surface texture.
- D. BellaLaminate Rails: Shall be 1/2"-thick (12.7mm), high-performance. Decorative laminate on 1/2" plywood (12.7mm).
- E. Aluminum Trim: Extruded 6063-T6 alloy.

2.04 FINISHES

- A. Wood Finish: Shall be factory-finished with two coats of catalyzed, clear conversion varnish.
- B. Aluminum Finish: Mill

2.05 FABRICATION

- A. Comply with requirements indicated for design, dimensions, details, finish, and member sizes.
- B. Factory-assemble components to the greatest extent possible. Disassemble only as necessary for shipping and handling.
- C. Fabricate components with tight seams and joints. Provide surfaces free of wrinkling, chipping, uneven coloration, dents, and other imperfections. Fabricate units and fittings to produce flush, smooth, and rigid hairline joints.
- D. Brackets, Flanges, Fittings, and Anchors: Provide wall brackets, flanges, and miscellaneous fittings for interconnection of units to other construction.

PART 3 EXECUTION

3.01 PREPARATION

- A. Provide horizontal structural blocking/back-up in wall to accept fasteners.
- B. Provide field "as-built-and-measured" cut-list to factory for fabrication of rail sections.
- C. Allow ten weeks for manufacture and supply of chair rail.

3.02 EXAMINATION

- A. Examine areas and conditions in which wall surface protection components and wall protection systems will be installed.
- B. Complete finishing operations, including painting, before beginning installation of wall surface protection system materials.
- C. Wall surfaces shall be dry and free from dirt, grease, loose paint, and scale.
- D. Do not proceed with installations until unsatisfactory conditions have been corrected.

3.03 INSTALLATION

- A. Install rail units plumb, level, and true to line without distortions.
- B. Do not use materials with chips, cracks, voids, stains, or other defects that might be visible.
- C. Install units in strict accordance with the manufacturer's instructions.
- D. Attachment hardware (supplied by others) shall be appropriate for wall construction.
- E. Where splices occur in horizontal runs of over 10-12 feet (3-4 m), splice applicable components at staggered locations along the run.

3.04 CLEANING

Immediately upon completion of installation, clean rails and accessories in accordance with manufacturer's recommended methods.



KOROGARD®
WALL PROTECTION SYSTEMS

800-628-0449 • www.korogard.com • Division 10 26 00